





|                       |        |                  |          |              |        |
|-----------------------|--------|------------------|----------|--------------|--------|
| Messrs.               |        |                  |          |              |        |
| Product Specification | Model: | MTF-TW70SN911-AV | Rev. No. | Issued Date. | Page.  |
|                       |        |                  | A        | Feb .23, 09  | 1 / 24 |

**LIQUID CRYSTAL DISPLAY MODULE**  
**MODEL: MTF-TW70SN911-AV**  
**Customer's No.:**

|            |
|------------|
| Acceptance |
|            |

*Microtips Technology Inc.*  
*12F. No.31 Lane 169, Kang Ning St.,*  
*His-Chih, Taipei Hsien, Taiwan*  
*FAX: 886-2-26958625*

|                         |
|-------------------------|
| Approved and Checked by |
|                         |

| Approved by   | Checked by  |  | Made by   |
|---|---|--|---|
|  |  |  |  |



*Microtips Technology Inc.*



|                       |        |                  |          |              |        |
|-----------------------|--------|------------------|----------|--------------|--------|
| Messrs.               |        |                  |          |              |        |
| Product Specification | Model: | MTF-TW70SN911-AV | Rev. No. | Issued Date. | Page.  |
|                       |        |                  | A        | Feb .23, 09  | 3 / 24 |

## Contents

|            |   |    |
|------------|---|----|
| <b>1.</b>  | <b>GENERAL DESCRIPTION AND FEATURES</b> ..... | 4  |
|            | 1.1 Features.....                             | 4  |
|            | 1.2 Control Features.....                     | 4  |
|            | 1.3 General Specifications .....              | 4  |
| <b>2.</b>  | <b>INPUT TERMINAL PIN ASSIGNMENT</b> .....    | 5  |
|            | 2.1 Pin Assignment .....                      | 5  |
|            | 2.2 Back-light Unit (BLU).....                | 6  |
| <b>3.</b>  | <b>BLOCK DIAGRAM</b> .....                    | 7  |
| <b>4.</b>  | <b>OPTICAL CHARACTERISTICS</b> .....          | 8  |
| <b>5.</b>  | <b>ABSOLUTE MAXIMUM RATINGS</b> .....         | 11 |
|            | 5.1 Absolute Ratings of Environment.....      | 11 |
|            | 5.2 Electrical Absolute Maximum Rating.....   | 11 |
|            | 5.3 TFT-LCD.....                              | 11 |
| <b>6.</b>  | <b>ELECTRICAL CHARACTERISTICS</b> .....       | 12 |
|            | 6.1 DC Electrical Characteristics.....        | 12 |
|            | 6.2 LED Driving Conditions.....               | 12 |
| <b>7.</b>  | <b>AC Characteristic</b> .....                | 13 |
|            | 7.1 MCU Interface Timing.....                 | 13 |
| <b>8.</b>  | <b>DISPLAYED COLOR AND INPUT DATA</b> .....   | 18 |
| <b>9.</b>  | <b>QUALITY ASSURANCE</b> .....                | 19 |
| <b>10.</b> | <b>PRECAUTIONS</b> .....                      | 20 |
|            | 10.1 Operation .....                          | 20 |
|            | 10.2 Safety .....                             | 20 |
|            | 10.3 Handling.....                            | 20 |
|            | 10.4 Static electricity .....                 | 22 |
|            | 10.5 Storage .....                            | 22 |
|            | 10.6 Cleaning .....                           | 22 |
|            | 10.7 Waste.....                               | 22 |
| <b>11.</b> | <b>WARRANTY</b> .....                         | 23 |
| <b>12.</b> | <b>DIMENSIONAL OUTLINES</b> .....             | 23 |



|                       |        |                  |          |              |        |
|-----------------------|--------|------------------|----------|--------------|--------|
| Messrs.               |        |                  |          |              |        |
| Product Specification | Model: | MTF-TW70SN911-AV | Rev. No. | Issued Date. | Page.  |
|                       |        |                  | A        | Feb .23, 09  | 4 / 24 |

## 1. GENERAL DESCRIPTION AND FEATURES

MTF-TW70SN911-AV is a TM (Transmissive) type color active matrix TFT (Thin Film Transistor) liquid crystal display (LCD) that uses amorphous silicon TFT as a switching device. This model is composed of a TFT-LCD module, a driver circuit and a back-light unit. The resolution of a 7" contains 800RGB×480 dots and can display up to 262K colors. The following table described the features of MTF-TW70SN911-AV.

### 1.1 Features

- Transmissive type with LED back-light.
- TN (Twisted Nematic) mode.
- Backlight LED-driving is not built-in this modul.

### 1.2 Control Features

- Support MCU Interface (Generic MPU bus interface)
- Embedded 896K SRAM display Buffer
- 

### 1.3 General Specifications

| Item               | Specification  | Unit |
|--------------------|--|------|
| Screen Size        | 7 inches diagonal  | inch |
| Display Resolution | 800 x RGB x 480  | Dot  |
| Pixel Pitch        | 190.5 (H) × 190.5 (V)  | um   |
| Active Area        | 152.4 (W) x 91.44 (H)  | mm   |
| Outline Dimension  | 165 (W) x 104.44 (H) x 10.4 (D)<br>Without FPCB tail & cable connector of BLU. | mm   |
| Weight             | TBD  | g    |
| Display Mode       | Normally white/Transmissive/Wide view  | --   |
| Pixel Arrangement  | RGB-Vertical Stripe  | --   |
| Surface Treatment  | Anti-Glare type  | --   |
| Viewing Direction  | 6 O'clock  | --   |
| Input Interface    | CPU (8/16/18 Interface) Data Transfer  | --   |

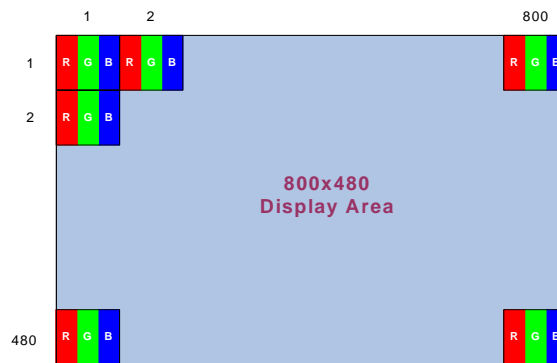

*Microtips Technology Inc.*

|                       |        |                  |          |              |        |
|-----------------------|--------|------------------|----------|--------------|--------|
| Messrs.               |        |                  |          |              |        |
| Product Specification | Model: | MTF-TW70SN911-AV | Rev. No. | Issued Date. | Page.  |
|                       |        |                  | A        | Feb .23, 09  | 5 / 24 |

## 2. INPUT TERMINAL PIN ASSIGNMENT

### 2.1 Pin Assignment

| Pin No. | Symbol | I/O | Function                                      | Remark |
|---------|--------|-----|---|--------|
| 1       | GND    | I   | GND   | --     |
| 2       | GND    | I   | GND   | --     |
| 3       | VDD    | I   | +3.3V power supply                            | --     |
| 4       | VDD    | I   | +3.3V power supply                            | --     |
| 5       | PWM    | O   | PWM output for backlight driver               | --     |
| 6       | RESET# | I   | Reset   | --     |
| 7       | DB17   | I/O | Display data                                  | --     |
| 8       | DB16   | I/O | Display data                                  | --     |
| 9       | DB15   | I/O | Display data                                  | --     |
| 10      | DB14   | I/O | Display data                                  | --     |
| 11      | DB13   | I/O | Display data                                  | --     |
| 12      | DB12   | I/O | Display data                                  | --     |
| 13      | DB11   | I/O | Display data                                  | --     |
| 14      | DB10   | I/O | Display data                                  | --     |
| 15      | DB9    | I/O | Display data                                  | --     |
| 16      | DB8    | I/O | Display data                                  | --     |
| 17      | DB7    | I/O | Display data                                  | --     |
| 18      | DB6    | I/O | Display data                                  | --     |
| 19      | DB5    | I/O | Display data                                  | --     |
| 20      | DB4    | I/O | Display data                                  | --     |
| 21      | DB3    | I/O | Display data                                  | --     |
| 22      | DB2    | I/O | Display data                                  | --     |
| 23      | DB1    | I/O | Display data                                  | --     |
| 24      | DB0    | I/O | Display data                                  | --     |
| 25      | CNF_A  | I   | H: 8080 mode L: 6800 mode                     | --     |
| 26      | WR#    | I   | VRAM write signal                             | --     |
| 27      | RD#    | I   | VRAM read signal                              | --     |
| 28      | RS     | I   | Register Select Signal; H: Data, Low: Command | --     |
| 29      | CS1#   | I   | Chip Select                                   | --     |



|                       |        |                  |          |              |        |
|-----------------------|--------|------------------|----------|--------------|--------|
| Messrs.               |        |                  |          |              |        |
| Product Specification | Model: | MTF-TW70SN911-AV | Rev. No. | Issued Date. | Page.  |
|                       |        |                  | A        | Feb .23, 09  | 6 / 24 |

|    |     |   |                    |    |
|----|-----|---|--------------------|----|
| 30 | VDD | I | +3.3V power supply | -- |
| 31 | VDD | I | +3.3V power supply | -- |
| 32 | GND | I | GND                | -- |
| 33 | GND | I | GND                | -- |

## 2.2 Back-light Unit (BLU)

| Pin No. | Symbol | Description            |
|---------|--------|------------------------|
| 1       | VLED + | Red , LED __ Anode     |
| 2       | VLED - | White , LED __ Cathode |

Note: The backlight interface connector is a model **SM02B-BHSS-1-TB** manufactured by JST or equivalent. The matching connector part number is **BHSR-20VS-1** manufactured by JST or equivalent.



|                       |        |                  |          |              |        |
|-----------------------|--------|------------------|----------|--------------|--------|
| Messrs.               |        |                  |          |              |        |
| Product Specification | Model: | MTF-TW70SN911-AV | Rev. No. | Issued Date. | Page.  |
|                       |        |                  | A        | Feb .23, 09  | 7 / 24 |

### 3. BLOCK DIAGRAM

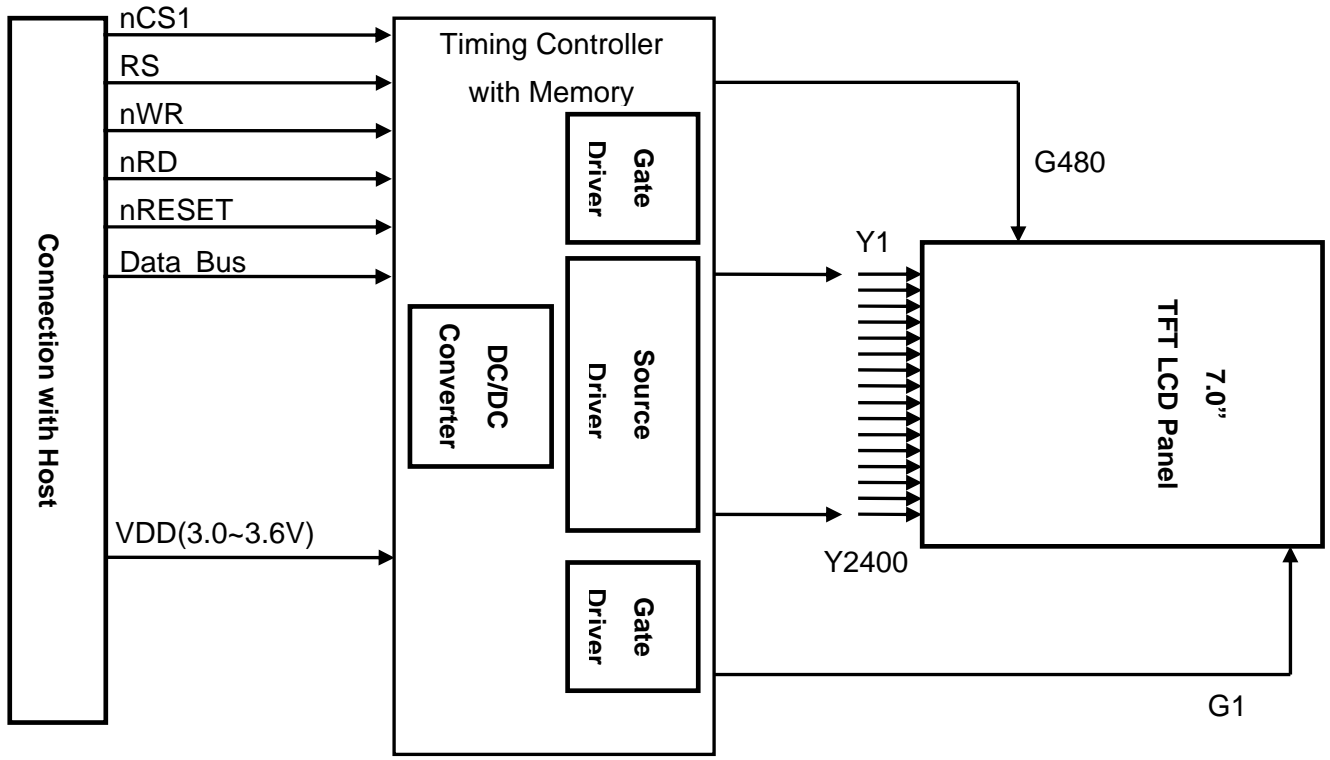

|                       |        |                  |          |              |        |
|-----------------------|--------|------------------|----------|--------------|--------|
| Messrs.               |        |                  |          |              |        |
| Product Specification | Model: | MTF-TW70SN911-AV | Rev. No. | Issued Date. | Page.  |
|                       |        |                  | A        | Feb .23, 09  | 8 / 24 |

#### 4. OPTICAL CHARACTERISTICS

The following items are measured under stable conditions. The optical characteristics should be measured in a dark room or equivalent state with the methods shown in Note (1).

Measuring equipment: LCD-5000, BM-5A, BM-7, PR-650, EZ-Contrast

( $T_a=25^{\circ}\text{C}$  ,  $I_F=200\text{mA}$ )

| Item                         | Symbol               | Condition                  | Min                            | Type        | Max   | Unit        | Note              |                   |
|------------------------------|----------------------|----------------------------|--------------------------------|-------------|-------|-------------|-------------------|-------------------|
| Response time                | $T_r$                | $\theta=0^{\circ}$         | --                             | 5           | 10    | ms          | Note 3,5          |                   |
|                              | $T_f$                | $\Phi=0^{\circ}$           | --                             | 11          | 16    | ms          |                   |                   |
| Contrast ratio               | CR                   | At optimized viewing angle | 250                            | 400         | --    | --          | Note 4,5          |                   |
| Color Chromaticity           | White                | $W_x$                      | $\theta=0^{\circ}$<br>$\Phi=0$ | Typ<br>0.03 | 0.299 | Typ<br>0.03 | --                | Note 2,6,7        |
| Color Saturation ( NTSC )    |                      | --                         | --                             | 45%         | --    | --          | Center of display |                   |
| Viewing Angle<br>(6 o'clock) | $\phi = 180^{\circ}$ | $\theta_l$                 | CR $\geq$ 10                   | 65          | 70    | --          | Degree            | Note 1            |
|                              | $\phi = 0^{\circ}$   | $\theta_R$                 |                                | 65          | 70    | --          |                   |                   |
|                              | $\phi = 90^{\circ}$  | $\theta_U$                 |                                | 55          | 60    | --          |                   |                   |
|                              | $\phi = 270^{\circ}$ | $\theta_D$                 |                                | 55          | 60    | --          |                   |                   |
| Brightness                   |                      | --                         | --                             | 300         | 350   | --          | cd/m <sup>2</sup> | Center of display |

Note 1: Definition of viewing angle range

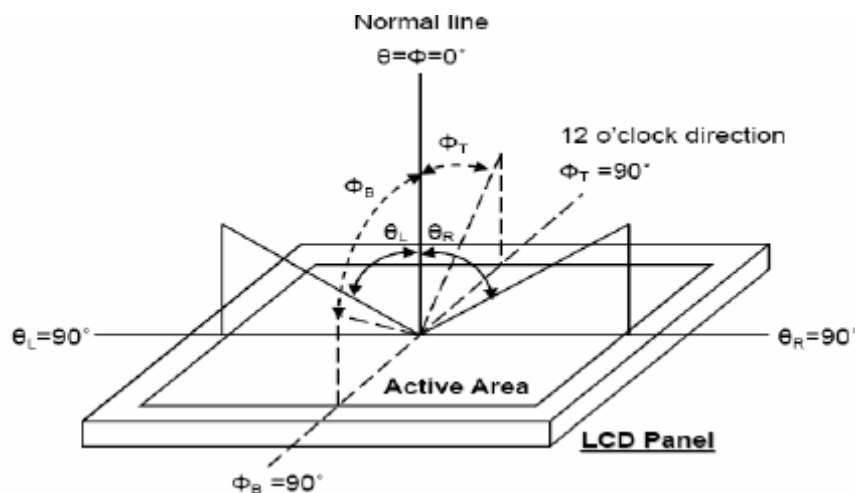

6 o'clock direction

Fig. 7-1 Definition of viewing angle



Microtips Technology Inc.

|                       |        |                  |          |              |        |
|-----------------------|--------|------------------|----------|--------------|--------|
| Messrs.               |        |                  |          |              |        |
| Product Specification | Model: | MTF-TW70SN911-AV | Rev. No. | Issued Date. | Page.  |
|                       |        |                  | A        | Feb .23, 09  | 9 / 24 |

Note 2: Test equipment setup:

After stabilizing and leaving the panel alone at a driven temperature for 10 minutes, the Measurement should be executed. Measurement should be executed in a stable, windless, and dark room. Optical specifications are measured by Topcon BM-7 Luminance meter 1.0° field of View at a distance of 50cm and normal direction.

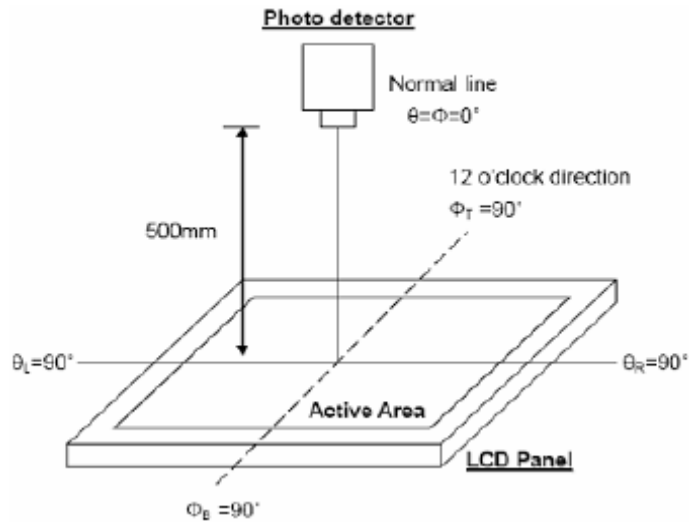

6 o'clock direction

**Fig. 7-2 Optical measurement system setup**

Note 3: Definition of Response time:

The response time is defined as the LCD optical switching time interval between “White state and “Black” state. Rise time,  $T_r$ , is the time between photo detector output intensity changed from 90% to 10%. And fall time,  $T_f$ , is the time between photo detector output Intensity changed from 90% to 10%.

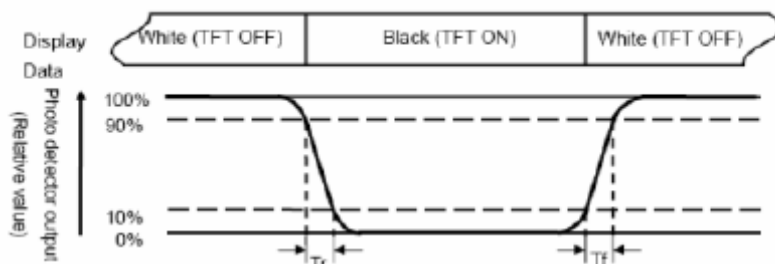

**Fig. 3-3 Definition of response time**



**Microtips Technology Inc.**

|                       |        |                  |          |              |         |
|-----------------------|--------|------------------|----------|--------------|---------|
| Messrs.               |        |                  |          |              |         |
| Product Specification | Model: | MTF-TW70SN911-AV | Rev. No. | Issued Date. | Page.   |
|                       |        |                  | A        | Feb .23, 09  | 10 / 24 |

Note 4: Definition of contrast ratio:

The contrast ratio is defined as the following expression:

$$\text{Contrast Ratio (CR)} = \frac{\text{Luminance measured when LCD on the "white state"}}{\text{Luminance measured when LCD on the "Black state"}}$$

Note 5: White  $V_i = V_{i50} \pm 1.5V$     Black  $V_i = V_{i50} \pm 20V$

“±” Means that the analog input swings in phase with VCOM signal.

“±” Means that the analog input swings out of phase with VCOM signal

The 100% transmission is defined as the transmission of LCD panel when all the input Terminals of module are electrically opened.

Note 6: Definition of color chromaticity (CIE 1931)

Color coordinates measured at the center point of LCD

Note 7: Measured at the center area of the panel when all the input terminals of LCD panel are electrically opened.

$$\text{Note 8: Uniformity (U)} = \frac{\text{Brightness ( min )}}{\text{Brightness ( max )}} \times 100\%$$



*Microtips Technology Inc.*

|                       |        |                  |          |              |         |
|-----------------------|--------|------------------|----------|--------------|---------|
| Messrs.               |        |                  |          |              |         |
| Product Specification | Model: | MTF-TW70SN911-AV | Rev. No. | Issued Date. | Page.   |
|                       |        |                  | A        | Feb .23, 09  | 11 / 24 |

## 5. ABSOLUTE MAXIMUM RATINGS

### 5.1 Absolute Ratings of Environment

If the operating condition exceeds the following absolute maximum ratings, the TFT LCD module may be damaged permanently.

(Ta=25°C, V<sub>SS</sub>=GND=0)

| Item                | Symbol          | Condition | Min. | Max.                 | Unit | Note   |
|---------------------|-----------------|-----------|------|----------------------|------|--------|
| Power Voltage       | V <sub>CC</sub> | GND=0     | -0.3 | 6                    | V    |        |
| Input Logic Voltage | V <sub>i</sub>  | GND=0     | -0.3 | V <sub>CC</sub> +0.3 | V    | Note 1 |

Note 1 : DCLK , DE , R0~R5 , G0~G5 , B0~B5.

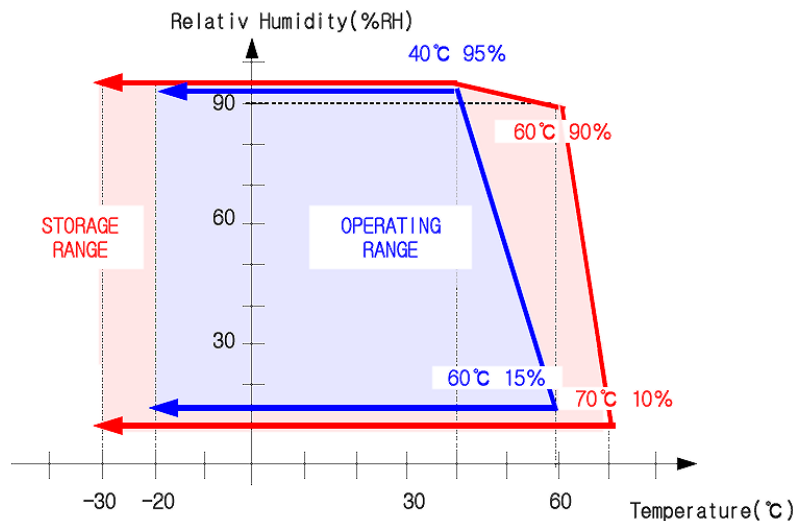

Note 2: In case of below 0°, the response time of liquid crystal (LC) becomes slower and the color of panel becomes darker than normal one. Level of retardation depends on temperature, because of LC's character

### 5.2 Electrical Absolute Maximum Rating

(Ta=25°C, V<sub>SS</sub>=GND=0)

| Parameter            | Symbol           | Min.               | Typ. | Max.               | Unit | Remark |
|----------------------|------------------|--------------------|------|--------------------|------|--------|
| Power Supply Voltage | V <sub>CC</sub>  | 3.0                | 3.3  | 3.6                | V    | --     |
| Logic Output Voltage | V <sub>OUT</sub> | 0                  | --   | 0.3V <sub>CC</sub> | V    | Note 1 |
| Input voltage        | V <sub>IH</sub>  | 0.7V <sub>CC</sub> | --   | V <sub>CC</sub>    | V    | Note 1 |

Note: Note 1 : DCLK , DE , R0~R5 , G0~G5 , B0~B5.



Microtips Technology Inc.

|                       |        |                  |          |              |         |
|-----------------------|--------|------------------|----------|--------------|---------|
| Messrs.               |        |                  |          |              |         |
| Product Specification | Model: | MTF-TW70SN911-AV | Rev. No. | Issued Date. | Page.   |
|                       |        |                  | A        | Feb .23, 09  | 12 / 24 |

### 5.3 TFT-LCD Current Consumption

| Parameter         | Symbol           | Rating |     |     | Unit | Condition    |
|-------------------|------------------|--------|-----|-----|------|--------------|
|                   |                  | Min    | Typ | Max |      |              |
| LCD Power current | I <sub>cc</sub>  | --     | 150 | 200 | ma   | Black pattem |
| LED Power current | I <sub>LED</sub> | --     | 160 | 200 | ma   | --           |

## 6. ELECTRICAL CHARACTERISTICS

### 6.1 DC Electrical Characteristics

(Ta=25±2°C, V<sub>SS</sub>=GND=0)

| Item                    | Symbol          | Min.            | Typ.               | Max. | Unit               | Remark |        |
|-------------------------|-----------------|-----------------|--------------------|------|--------------------|--------|--------|
| Power Supply Voltage    | V <sub>CC</sub> | 3.0             | 3.3                | 3.6  | V                  | --     |        |
| Input Voltage for logic | Low Level       | V <sub>IL</sub> | 0                  | --   | 0.3V <sub>CC</sub> | V      | Note 1 |
|                         | High Level      | V <sub>IH</sub> | 0.7V <sub>CC</sub> | --   | V <sub>CC</sub>    | V      | Note 1 |

Note 1 : DCLK , DE , R0~R5 , G0~G5 , B0~B5.

### 6.2 LED Driving Conditions

| Parameter     | Symbol           | Min    | Typ    | Max | Unit | Remark |
|---------------|------------------|--------|--------|-----|------|--------|
| LED current   | I <sub>LED</sub> | --     | 160    | --  | mA   | Note 1 |
| LED voltage   | V <sub>LED</sub> | --     | 9.9    | --  | V    | --     |
| LED Life Time | --               | 10,000 | 20,000 | --  | Hr   | Note 2 |

Note 1: There are 8 Groups LED shown as below , V<sub>LED</sub>=9.9V, I<sub>LED</sub>=160mA.

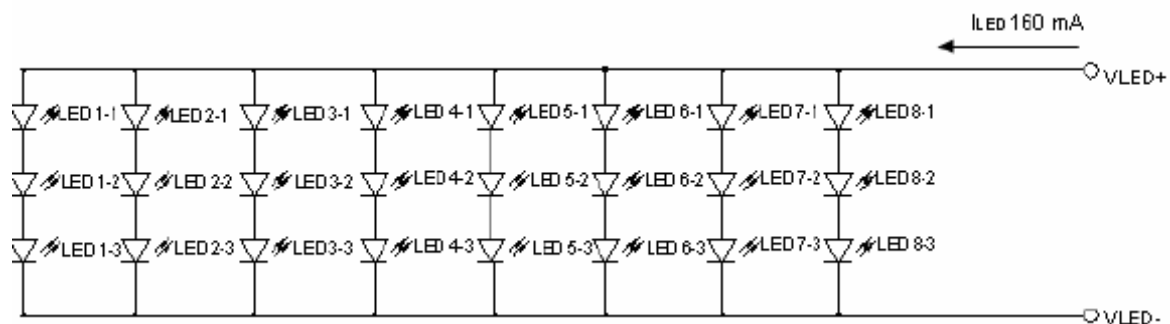

Note 2: Brightness to be decreased to 50% of the initial value.



Microtips Technology Inc.

|                       |        |                  |          |              |         |
|-----------------------|--------|------------------|----------|--------------|---------|
| Messrs.               |        |                  |          |              |         |
| Product Specification | Model: | MTF-TW70SN911-AV | Rev. No. | Issued Date. | Page.   |
|                       |        |                  | A        | Feb .23, 09  | 13 / 24 |

## 7. AC Characteristic

Conditions:

Voltage referenced to VSS  
VDD, VDDPLL=1.2V±0.1V  
VDDIO, VDDLCD=3.3V±10%  
TA= -30°C to 85°C  
CL=50pF (Bus/CPU Interface)  
CL=0pF (LCD Panel Interface)

### 7.1 MCU Interface Timing

#### 7.1.1 Parallel 6800-series Interface Timing

Parallel 6800-series Interface Timing Characteristics

| Symbol             | Parameter                  | Min | Typ | Max | Unit             |
|--------------------|----------------------------|-----|-----|-----|------------------|
| t <sub>CYC</sub>   | Reference Clock Cycle Time | 9   | --  | --  | ns               |
| t <sub>PWCSL</sub> | Control Pulse Low Width    | 1   | --  | --  | t <sub>CYC</sub> |
| t <sub>PWCSH</sub> | Control Pulse High Width   | 1   | --  | --  | t <sub>CYC</sub> |
| t <sub>FDRD</sub>  | First Data Read Delay      | 5   | --  | --  | t <sub>CYC</sub> |
| t <sub>AS</sub>    | Address Setup Time         | 1   | --  | --  | ns               |
| t <sub>AH</sub>    | Address Hold Time          | 1   | --  | --  | ns               |
| t <sub>DSW</sub>   | Data Setup Time            | 4   | --  | --  | ns               |
| t <sub>DHW</sub>   | Data Hold Time             | 1   | --  | --  | ns               |
| t <sub>DSR</sub>   | Data Access Time           | --  | --  | 5   | ns               |
| t <sub>DHR</sub>   | Output Hold Time           | 1   | --  | --  | ns               |





Messrs.

Product Specification

Model:

MTF-TW70SN911-AV

Rev. No.

A

Issued Date.

Feb .23, 09

Page.

15 / 24

Parallel 6800-series Interface Timing Diagram (Use E as Clock)

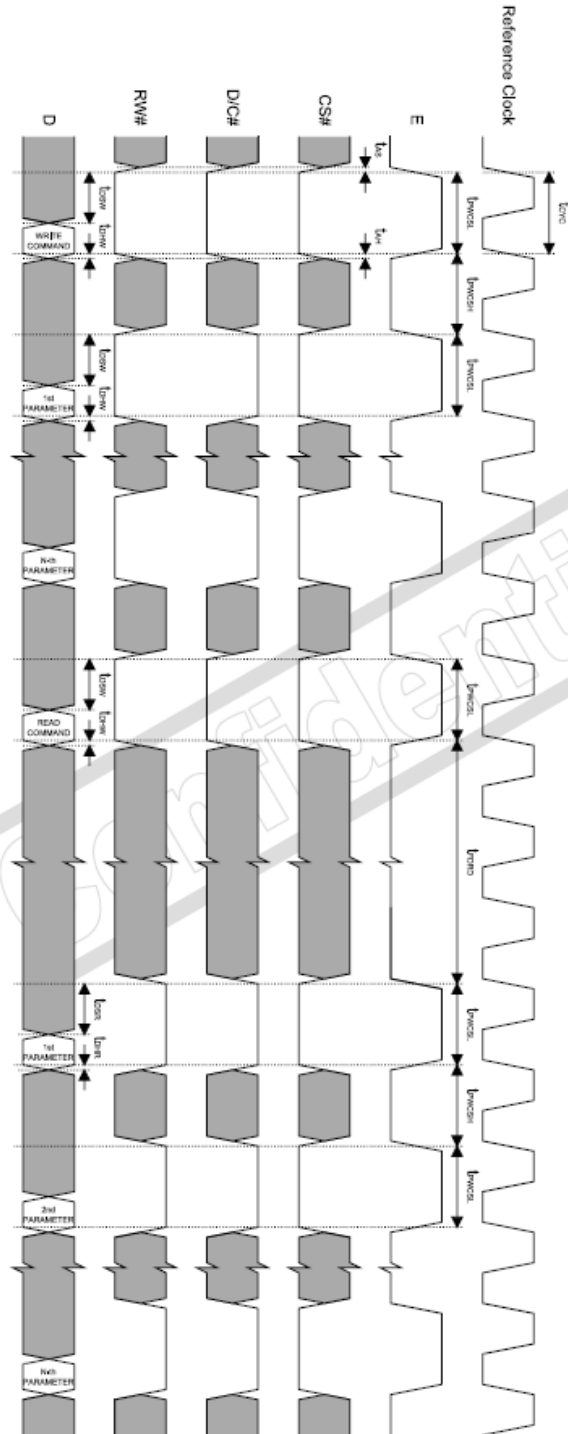

Microtips Technology Inc.

|                       |        |                  |          |              |         |
|-----------------------|--------|------------------|----------|--------------|---------|
| Messrs.               |        |                  |          |              |         |
| Product Specification | Model: | MTF-TW70SN911-AV | Rev. No. | Issued Date. | Page.   |
|                       |        |                  | A        | Feb .23, 09  | 16 / 24 |

### 7.1.2 Parallel 8008-series Interface Timing

#### Parallel 8080-series Interface Timing Characteristics

| Symbol      | Parameter                  | Min | Typ | Max | Unit      |
|-------------|----------------------------|-----|-----|-----|-----------|
| $t_{CYC}$   | Reference Clock Cycle Time | 9   | --  | --  | ns        |
| $t_{PWCSL}$ | Control Pulse Low Width    | 1   | --  | --  | $t_{CYC}$ |
| $t_{PWCSH}$ | Control Pulse High Width   | 1   | --  | --  | $t_{CYC}$ |
| $t_{FDRD}$  | First Data Read Delay      | 5   | --  | --  | $t_{CYC}$ |
| $t_{AS}$    | Address Setup Time         | 1   | --  | --  | ns        |
| $t_{AH}$    | Address Hold Time          | 1   | --  | --  | ns        |
| $t_{DSW}$   | Data Setup Time            | 4   | --  | --  | ns        |
| $t_{DHW}$   | Data Hold Time             | 1   | --  | --  | ns        |
| $t_{DSR}$   | Data Access Time           | --  | --  | 5   | ns        |
| $t_{DHR}$   | Output Hold Time           | 1   | --  | --  | ns        |





|                       |        |                  |          |              |         |
|-----------------------|--------|------------------|----------|--------------|---------|
| Messrs.               |        |                  |          |              |         |
| Product Specification | Model: | MTF-TW70SN911-AV | Rev. No. | Issued Date. | Page.   |
|                       |        |                  | A        | Feb .23, 09  | 18 / 24 |

## 8. DISPLAYED COLOR AND INPUT DATA

| Interface            | Cycle           | D[17] | D[16] | D[15] | D[14] | D[13] | D[12] | D[11] | D[10] | D[9] | D[8] | D[7] | D[6] | D[5] | D[4] | D[3] | D[2] | D[1] | D[0] |
|----------------------|-----------------|-------|-------|-------|-------|-------|-------|-------|-------|------|------|------|------|------|------|------|------|------|------|
| 18 bits              | 1 <sup>st</sup> | R5    | R4    | R3    | R2    | R1    | R0    | G5    | G4    | G3   | G2   | G1   | G0   | B5   | B4   | B3   | B2   | B1   | B0   |
| 16 bits (565 format) | 1 <sup>st</sup> |       |       | R5    | R4    | R3    | R2    | R1    | G5    | G4   | G3   | G2   | G1   | G0   | B5   | B4   | B3   | B2   | B1   |
| 16 bits              | 1 <sup>st</sup> |       |       | R5    | R4    | R3    | R2    | R1    | R0    | X    | X    | G5   | G4   | G3   | G2   | G1   | G0   | X    | X    |
|                      | 2 <sup>nd</sup> |       |       | B5    | B4    | B3    | B2    | B1    | B0    | X    | X    | R5   | R4   | R3   | R2   | R1   | R0   | X    | X    |
|                      | 3 <sup>rd</sup> |       |       | G5    | G4    | G3    | G2    | G1    | G0    | X    | X    | B5   | B4   | B3   | B2   | B1   | B0   | X    | X    |
| 8 bits               | 1 <sup>st</sup> |       |       |       |       |       |       |       |       |      |      | R5   | R4   | R3   | R2   | R1   | R0   | X    | X    |
|                      | 2 <sup>nd</sup> |       |       |       |       |       |       |       |       |      |      | G5   | G4   | G3   | G2   | G1   | G0   | X    | X    |
|                      | 3 <sup>rd</sup> |       |       |       |       |       |       |       |       |      |      | B5   | B4   | B3   | B2   | B1   | B0   | X    | X    |

X: Don't Care



|                       |        |                  |          |              |         |
|-----------------------|--------|------------------|----------|--------------|---------|
| Messrs.               |        |                  |          |              |         |
| Product Specification | Model: | MTF-TW70SN911-AV | Rev. No. | Issued Date. | Page.   |
|                       |        |                  | A        | Feb .23, 09  | 19 / 24 |

## 9. QUALITY ASSURANCE

| No. | Test Item   | Test Condition  | Remark |
|-----|---|---|--------|
| 1   | High Temperature Storage Test                     | Ta= 80°C Dry 240 Hrs  | --     |
| 2   | Low Temperature Storage Test                      | Ta= 30°C Dry 240 Hrs  | --     |
| 3   | High Temperature Operation Test                   | Ta= 70°C Dry 240 Hrs  | --     |
| 4   | Low Temperature Operation Test                    | Ta= -20°C Dry 240 Hrs   | --     |
| 5   | High Temperature and High Humidity Operation Test | Ta = 60°C 90%RH 240 Hrs   | --     |
| 6   | Electro Static Discharge Test                     | 150pF , 330Ω, ±8KV(Contact)/±15KV(Air), 5points/panel, 5times/point                           | --     |
| 7   | Shock Test (non-operating)                        | Half sine wave, 180G, 2ms one Shock of each six faces ( I.e. run 180G, 2ms for all six faces) | --     |
| 8   | Vibration Test (non-operating)                    | Sine wave, 10 ~ 500 ~ 10Hz , 1.5G, 0.37oct/min 3axis, 1hour/axis                              | --     |
| 9   | Thermal Shock Test                                | -20°C(0.5h) ~ 70°C(0.5h ) / 100 cycles(Dry)   | --     |

\*\*\*\*\* Ta = Ambient Temperature



*Microtips Technology Inc.*

|                       |        |                  |          |              |         |
|-----------------------|--------|------------------|----------|--------------|---------|
| Messrs.               |        |                  |          |              |         |
| Product Specification | Model: | MTF-TW70SN911-AV | Rev. No. | Issued Date. | Page.   |
|                       |        |                  | A        | Feb .23, 09  | 20 / 24 |

## 10. PRECAUTIONS





### 10.1 Operation

Burn-in sometimes happens when the same character was displayed at along time. Therefore, to prevent Burn-in, it is recommended to set up a Screen-saver function.

### 10.2 Safety

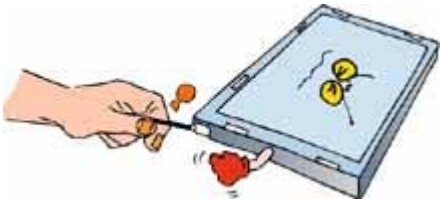



The liquid crystal in the LCD is poisonous, DO NOT put it in your mouth. If the liquid crystal touches your skin or clothes, wash it off immediately using soap and water.

### 10.3 Handling

|   |   |
|---|---|
|    | <ul style="list-style-type: none"> <li>a. The LCD module shall be installed flat, without twisting or bending.</li> <li>b. COF or FPC has narrow pattern width, so easily become open circuit by external force. DO NOT apply pressure to COF or FPC especially in bending area.</li> </ul> |
|   | <ul style="list-style-type: none"> <li>c. To avoid damage in appearance or malfunction, DO NOT subject the module to mechanical shock or to excessive force on its surface.</li> </ul>  |
|  | <ul style="list-style-type: none"> <li>d. The polarizer attached to the display is very easy to be damaged, handle it with care to avoid scratching.</li> </ul>   |
|  | <ul style="list-style-type: none"> <li>e. To avoid contamination on the display surface, DO NOT touch the display surface with bare hands.</li> <li>f. Provide a space so that the LCD module does not come into contact with other components.</li> </ul>                                  |

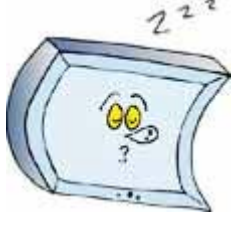
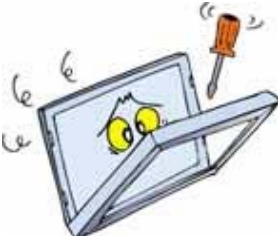

| Product Specification | Model: | MTF-TW70SN911-AV | Rev. No. | Issued Date. | Page.   |
|-----------------------|--------|------------------|----------|--------------|---------|
|                       |        |                  | A        | Feb .23, 09  | 21 / 24 |

|   |   |
|---|---|
|    | <p>g. To protect the LCD panel from external pressure, put covering glass (acrylic board or similar board) to keep appropriate space between them.</p>  |
|    | <p>h. Be careful for condensation at sudden temperature change. Condensation makes damage to polarizer or electrical contacted parts. And after fading condensation, smear or spot will occur.</p>  |
|   | <p>i. Property of semiconductor devices may be affected when they are exposed to light possibly resulting in malfunctioning of the ICs. To prevent such malfunctioning of the ICs, your design and mounting layout done are so that the IC is not exposed to light in actual use.</p>                                     |
|  | <p>j. Strong light exposure causes degradation of color filter. It may not recover</p>  |
|  | <p>k. DO NOT contact with water to avoid Metal corrosion.</p> <p>l. When it is not in use, the screen must be turned off or the pattern must be frequently changed by a screen saver. If it displays the same pattern for a long period of time, brightness down/image sticking may develop due to the LCD structure.</p> |
|  | <p>m. Never disassemble LCD product under any circumstances. If unqualified operators or users assemble the product after disassembling it, it may not function or its operation may be seriously affected.</p>   |



|                       |        |                  |          |              |         |
|-----------------------|--------|------------------|----------|--------------|---------|
| Messrs.               |        |                  |          |              |         |
| Product Specification | Model: | MTF-TW70SN911-AV | Rev. No. | Issued Date. | Page.   |
|                       |        |                  | A        | Feb .23, 09  | 22 / 24 |

#### 10.4 Static electricity

Since a module is composed of electronic circuits, it is not strong to electrostatic discharge.

|   |  |
|---|--|
|  | <ul style="list-style-type: none"> <li>a. The LCD module shall be installed flat, without twisting or bending. Ground soldering iron tips, tools and testers when they operate.</li> <li>b. Ground your body when handling the products.</li> <li>c. DO NOT apply voltage to the input terminal without applying power supply.</li> <li>d. DO NOT apply voltage that exceeds the absolute maximum rating.</li> <li>e. Store the products in an anti-electrostatic container.</li> <li>f. Peel off protect tape, attached to polarizer, slowly to minimize ESD damage.</li> </ul> |
|---|--|

#### 10.5 Storage

|   |  |
|---|--|
|  | <p>Store the products in a dark place at +5 ~ +25 degree C, low humidity (50%RH or less).<br/>DO NOT store the products in an atmosphere containing organic solvents or corrosive gases.</p> |
|---|--|

#### 10.6 Cleaning

|   |  |
|---|--|
|  | <ul style="list-style-type: none"> <li>a. DO NOT wipe the polarizer with dry cloth, as it might cause scratch.</li> <li>b. Wipe the polarizer with a soft cloth soaked with petroleum IPA, other chemical might damage.</li> </ul> |
|---|--|

#### 10.7 Waste

|   |  |
|---|--|
|  | <p>When dispose of LCD module, manage it at the production waste according to the relevant laws and regulations.</p> |
|---|--|



|                       |        |                  |          |                    |                |
|-----------------------|--------|------------------|----------|--------------------|----------------|
| Messrs.               |        |                  |          |                    |                |
| Product Specification | Model: | MTF-TW70SN911-AV | Rev. No. | Issued Date.       | Page.          |
|                       |        |                  | A        | <i>Feb .23, 09</i> | <i>23 / 24</i> |

## 11. WARRANTY

This product has been manufactured to your company's specifications as a part for use in your This product has been manufactured to your company's specifications as a part for use in your company's general electronic products. It is guaranteed to perform according to delivery specifications. For any other use apart from general electronic equipment, we cannot take responsibility if the product is used in medical devices, nuclear power control equipment, aerospace equipment, fire and security systems, or any other applications in which there is a direct risk to human life and where extremely high levels of reliability are required. If the product is to be used in any of the above applications, we will need to enter into a separate product liability agreement.

- 1 13 months guarantee starts from the date code.
- 2 We cannot accept responsibility for any defect, which may arise from additional manufacturing of the product (including disassembly and reassembly), after product delivery.
- 3 We cannot accept responsibility for any defect, which may arise after the application of strong external force to the product.
- 4 We cannot accept responsibility for any defect, which may arise due to the application of static electricity after the product has passed your company's acceptance inspection procedures.
- 5 We cannot accept responsibility for industrial property, which may arise through the use of your product, with exception to those issues relating directly to the structure or method of manufacturing of our product. Microtips-origin longer than one year from Microtips production.

## 12. DIMENSIONAL OUTLINES

See next page.....



*Microtips Technology Inc.*

